

Shelbourne

REYNOLDS



CUBICLE
BEDDER
&
BUCKET
SHEAR

Shelbourne

CUBICLE BEDDER



OPTIONAL 3 POINT LINKAGE HYDRAULIC TIPPING FRAME WITH "A" FRAME ATTACHMENT

THE SHELBOURNE CUBICLE BEDDER IS DESIGNED TO PROVIDE A UNIFORM BED QUICKLY AND EFFICIENTLY WITH A MINIMUM OF OPERATOR EFFORT.



The machine consists of a rugged, welded steel bucket with a 30cm wide, hydraulically driven, seamless cleated belt running in the bottom.

This belt will operate in either direction, allowing the operator to bed cubicles on either side of the machine while keeping dust levels to a minimum.

- SAVE TIME
- SAVE BEDDING, USE UP TO 50% LESS BEDDING MATERIAL
- MORE EVENLY DISTRIBUTED BEDDING
- SAME MACHINE AVAILABLE EITHER AS REAR 3-POINT MOUNTED WITH TIPPING FRAME OR AS FRONT LOADER MOUNTED
- SIMPLE DURABLE DESIGN
- ONE HYDRAULIC FLOW AND RETURN NEEDED



The Shelbourne Cubicle Bedder is the most versatile machine of it's type available. Discharge rates can be changed by either adjusting the internal slides, or varying the speed of the belt using the tractor/loader hydraulic flow control. These factors, along with forward speed adjustments gives the operator complete control.

The belt speed can be used to control the distance material is thrown with a maximum of 10ft possible.

A centrally mounted agitator shaft is operated hydraulically above the belt using a common hydraulic supply. Agitator tines can be mounted in pairs to prevent bridging and ensure even feeding down on to the belt. These can be removed depending on the type of material used.



▲ OPTIONAL 3 POINT LINKAGE BRACKETS

The Shelbourne Cubicle Bedder can be used on a wide range of materials including sawdust, wood shavings, processed paper, chopped straw, sand and green bedding.

“ THE SAME MACHINE CAN SPREAD SAND, SAWDUST, ENVIROBED, STRAW, GREEN BEDDING, LIME AND STRAW, GYPSUM AND EVERYTHING ELSE WE HAVE COME ACROSS TO DATE! ”

HEAVY DUTY INTERNAL AGITATOR AND DISCHARGE CONTROL SLIDES



CHAIN DRIVE AGITATOR



FLOW CONTROL VALVE



ONE PIECE BELT



Shelbourne

PARMITER SHEAR BUCKET



THE PARMITER SHEAR BUCKET IS THE MOST VERSATILE MACHINE THAT YOU WILL EVER OWN!

It has the unique ability to neatly cut silage blocks leaving a sealed face yet retains the versatile characteristics of a normal bucket for handling loose feedstuffs.

All of these functions and operations are possible with no adjustments and without leaving the seat of the tractor/handler.

The Parmiter Shear Bucket effectively replaces both a conventional silage grab and bucket with one machine. Heavy duty hydraulic cylinders power the front blade and two side blades down through the silage, while the bucket complete with bladed edges holds the block stable.

There is only one moving part so wear and adjustment is minimised. Four greasing points reduce maintenance to a minimum.

Rugged construction and simple design including wear strips on the underside of the bucket ensure a reliable durable machine.



BOLT ON LOADER AND
HANDLER BRACKETS AVAILABLE

PARMITER SHEAR BUCKET





CUBICLE BEDDER TECHNICAL DATA

MODEL	MACHINE CAPACITY	OVERALL HEIGHT (A)	OVERALL DEPTH (B)	OVERALL WIDTH (C)	TUB WIDTH (D)	TUB DEPTH (E)	WIDTH OF DISCH. BELT (E)	STANDARD HYD CON. MOTOR	MEDIUM HYD CON. MOTOR	LOW HYD CON. MOTOR	MIN HYD OIL PRESSURE	MAX HYD OIL PRESSURE	OPTIMUM HYD OIL FLOW	MAX HYD OIL FLOW	WEIGHT	MIN TRACTOR SIZE
CB100	0.6m ³	1170 mm	1235 mm	1600 mm	1370 mm	1150 mm	300 mm	30-35 l/min	24-28 l/min	15-22 l/min	125 bar	180 bar	30-35 l/min	60 l/min	440kg	30hp
CB150	1.2m ³	1390 mm	1420 mm	1900 mm	1670 mm	1390 mm	300 mm	30-35 l/min	24-28 l/min	15-22 l/min	125 bar	180 bar	30-35 l/min	60 l/min	530kg	30hp
CB300	1.45m ³	1390 mm	1420 mm	2200 mm	1970 mm	1390 mm	300 mm	30-35 l/min	24-28 l/min	15-22 l/min	125 bar	180 bar	30-35 l/min	60 l/min	580kg	30hp

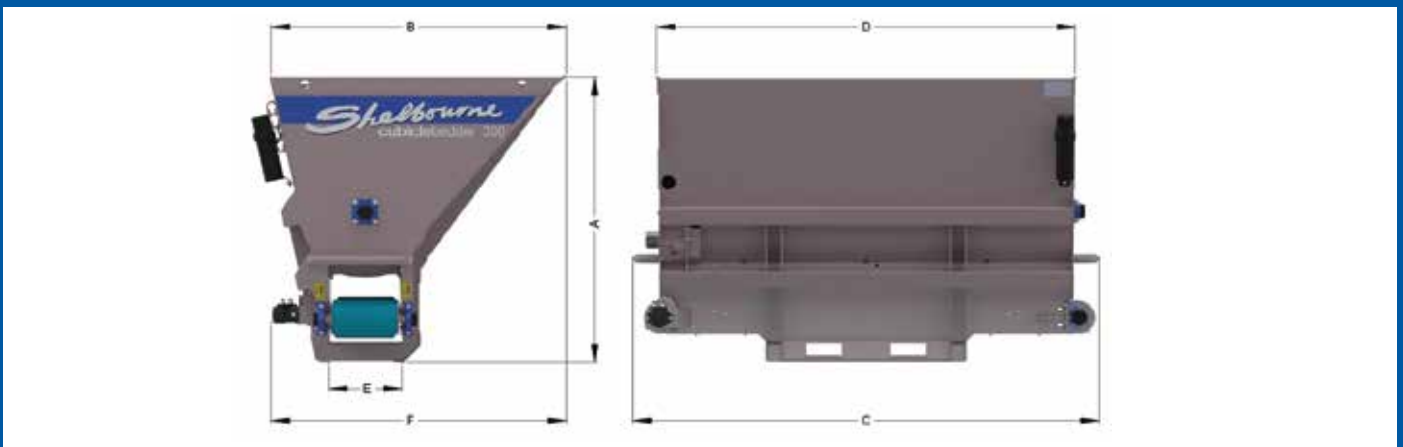

PARMITER SHEAR BUCKET TECHNICAL DATA

MODEL	WIDTH (A)	DEPTH (B)	HEIGHT (C)	CAPACITY	VOLUME	NO OF HYD RAMS
SB250	1.68m	0.8m	0.8m	644kg	1.08cm	2
SB300	2.0m	0.8m	0.8m	787kg	1.28cm	2

